

# SR02-BB 1U/2U Sliding Rail Installation

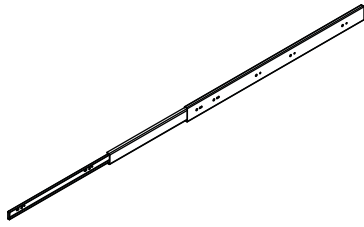

## Included in this package

(2) 20"/26" Sliding Rail



(8) #10-32 x 5/8 Screws



(8) M4 x 8 Screws



(8) M4 Hex Nuts



(4) "L" Ear Bracket

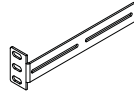

## Installation Steps

- 1 Holding the 20"/26" sliding rail on one hand then pull the center slide (traveling slide) all the way out until it stops. You will see a plastic clip at the end point of center slide. Pushing down the plastic lever to unlock the center slide from housing than pull the traveling slide.

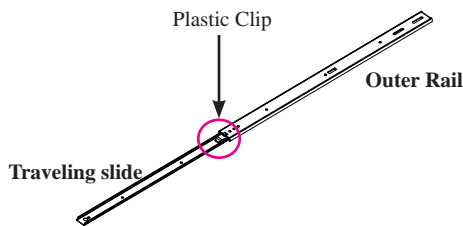

- 3 Attach the front ear bracket with rail to the cabinet as show below. Use included rack screws to secure front ear bracket first. Extend rear bracket to reach the rear vertical mounting rail. Tighten all rack screws, M4 screws and nuts.

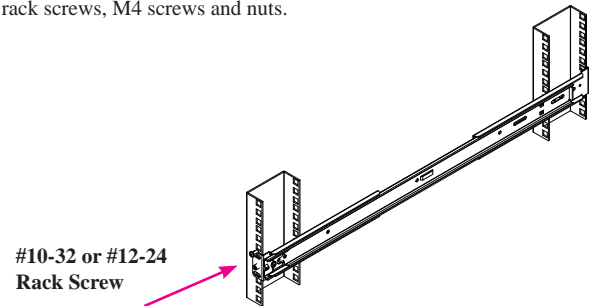

- 2 Once traveling slide is removed. You can access to M4 mounting screws for the front and rear ear brackets. Loosening the hex nuts to adjust ear bracket position.

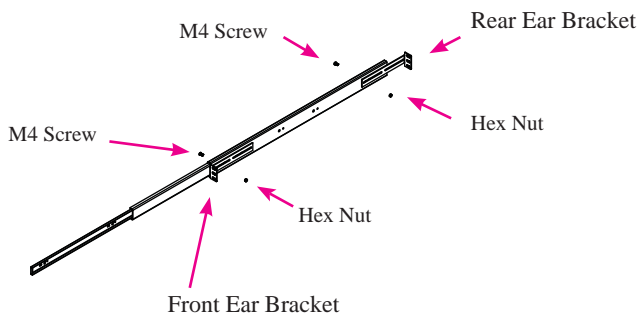

- 4 Repeat Step 1 to 3 for right hand side rail and ear bracket.

- 5 Align mounting holes on traveling slide with your 1U /2U rackmount equipment or shelf. At least 2 mounting holes is required for proper sliding rail installation. If your equipment or shelf does not have at least 2 matching mounting holes, you might need to drill holes at the traveling slide to ensure proper installation. Custom drilling procedure is beyond scope of this installation instruction. You will need to seek professional assistance for custom drilling hole.

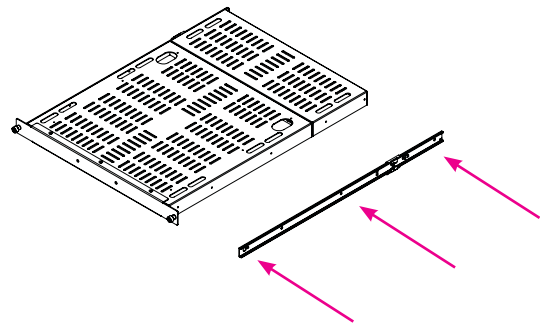

If you have problem installing your sliding rail, please contact us for assistance.