

IRP208DB-6U 6U DIN Rail Panel Installation

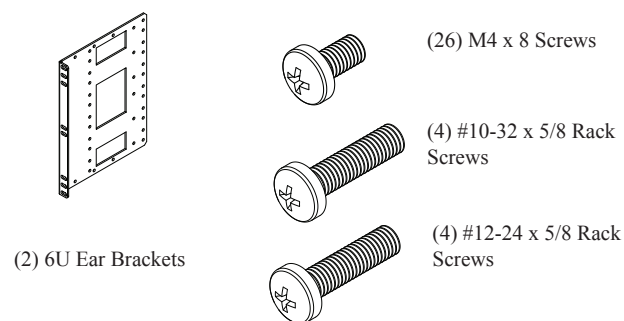

Included in this package

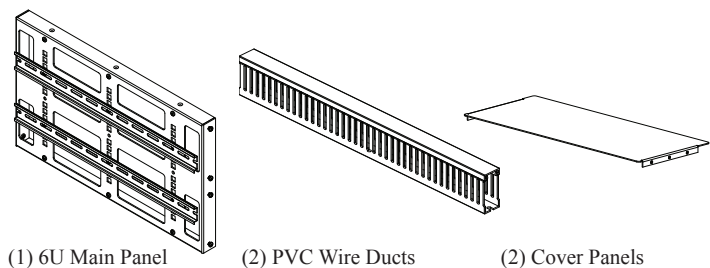

Installation Steps

Step 1 Installing PVC Wire Duct

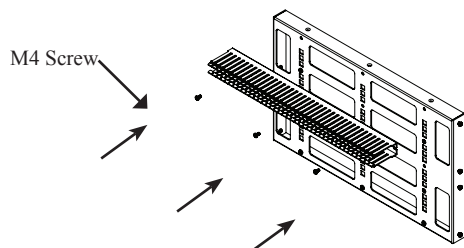

Step 2 Installing Bottom PVC wire Duct

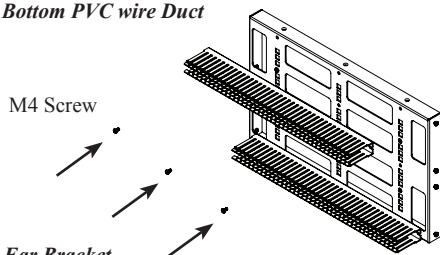

Step 3 Installing Ear Bracket

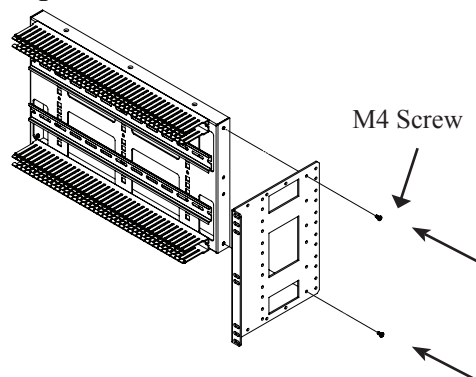

Note: Bottom screw might be little tight when screw in. That is normal.

Step 4 Installing middle screws

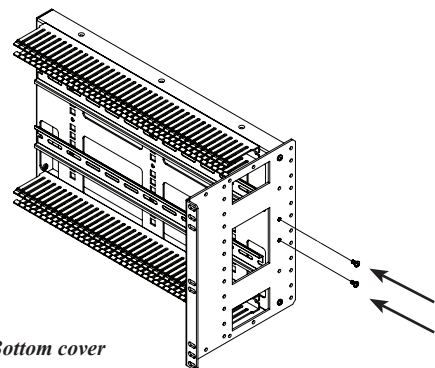

Step 5 Installing Bottom cover

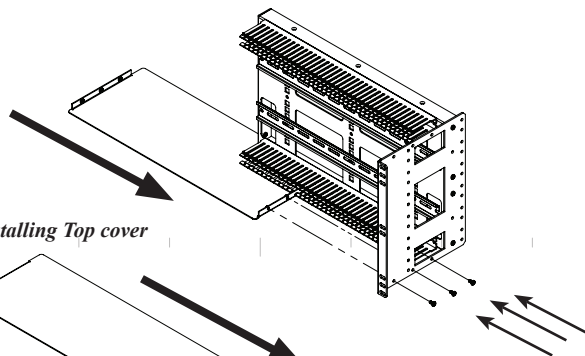

Step 6 Installing Top cover

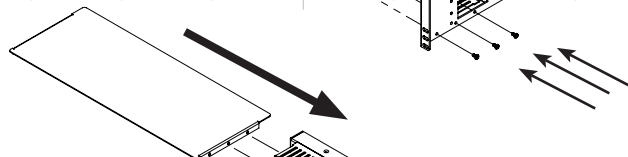

Step 7 Installing Ear Bracket

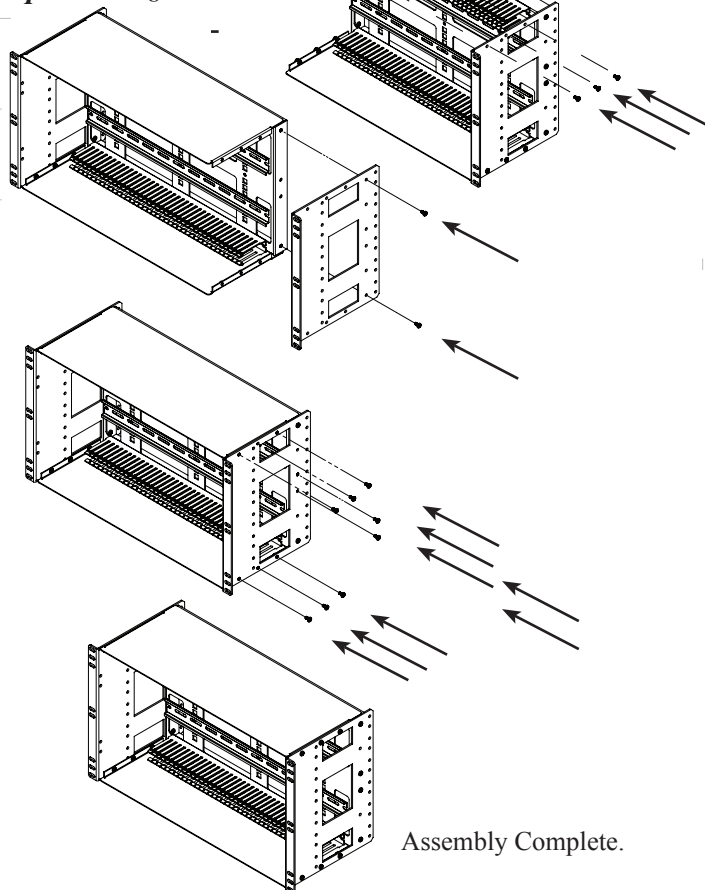

Assembly Complete.